

INSTRUCTION MANUAL
FOR
MODELS 61VSA & 62VSA
VARIABLE SPEED
SNAGGING GRINDERS

INDEX	Page
Section I	
General Information	2
Care and Maintenance Instructions	3
Parts Illustrations	5
Parts List	11

U.S. ELECTRICAL TOOL INC.

5928 Hamilton Cleves Rd.
Miamitown, OH 45041-0230

513-353-3660
513-353-4040 Fax

www.uselectricaltool.com
sales@uselectricaltool.com

U.S. VARIABLE SPEED SNAGGING GRINDERS

Models 61VSA and 62VSA

U.S. Pat. No. 3157006

GENERAL INFORMATION

Maximum safety, productivity and economy are designed into every U.S. Variable Speed Snagging Grinder. Compare these unique features:

- Correct peripheral speed maintained regardless of wheel diameter.
- Patented variable speed principle eliminates mechanical linkage to prevent overspeeding.
- Extra heavy duty spindle bearings permanently lubricated and sealed.
- One piece, extra heavy guard construction having no moving parts.
- Hinged guard door with quick acting latches forms solid enclosure.
- Dual wheel rests facilitate wheel installation.
- TEFC motor enclosed in fabricated steel base.
- Simple sheave change establishes alternate speed range.

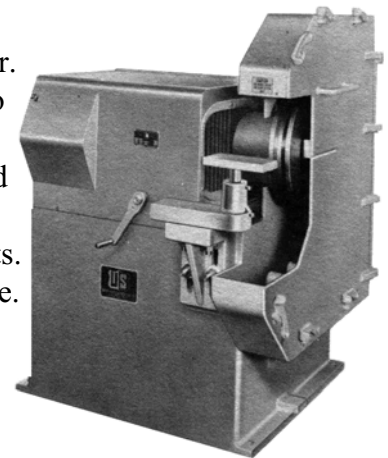

Termed “Grinder with a Brain”, the U.S. “Wheel to the Work” principle permits infinite hand crank adjustment of the wheel within the guard to compensate for wheel wear. By maintaining the 1/8” gauge clearance, the correct peripheral speed is automatically set regardless of wheel diameter and it is maintained throughout the extended life of the wheel. No mechanical linkage required to prevent overspeeding. Hazardous movable and multi-section guards have been replaced by a solid enclosure. Guesswork is eliminated and safety is assured. U.S. Variable Speed Grinders are fool-proof and tamper-proof.

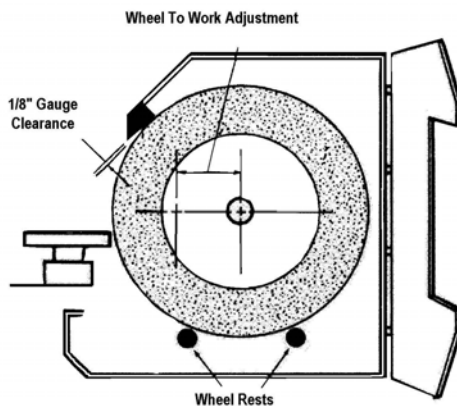

Pressure fixture work is easily accommodated without constant readjustment and alignment of the tool support. Moving the “Wheel to the Work” reestablishes gauge clearance without disturbing the initial setup.

Another exclusive U.S. feature is the wheel rests incorporated in the guard enclosure to facilitate wheel installation. The wheel rests support and locate the wheel in approximate position while final alignment on the inner flange is achieved. A spindle nut wrench is furnished.

CARE AND MAINTENANCE INSTRUCTIONS
MODELS 61VSA & 62VSA SNAGGING GRINDERS

INSTALLATION:

Secure this machine to a solid foundation. Refer to the nameplate nomenclature before connecting power lines to this machine.

The spindle nut and outside wheel flange should be removed before starting machine to check rotation of spindle, The spindles (s) should run "DOWN".

OPERATION:

This machine is designed and built as a high-speed, heavy-duty snagging grinder. To adjust spindle for mounting of wheel, first start unit. Do not turn speed adjustment (14) unless motor is running. Extreme care should be exercised in the handling and mounting of grinding wheels.

CAUTION:

Use wheels that are properly rated for the speed of this unit; refer to nameplate. The wheel flange must be set into place, and not forced. We recommend use of wheel blotters between grinding wheel and flanges. These are readily available from your wheel source.

To maintain the proper wheel speed for maximum efficiency, the wheel should be adjusted to within 1/8" of the guard lip at all times. To adjust wheel, turn speed adjustment located on the front of the machine.

MAINTENANCE:

Lubrication:

Ball Bearings (6 & 10) are of the permanently lubricated type and require no further lubrication. Feed screw nut should be lubricated monthly utilizing any good grade acid free grease via grease fitting at rear of spindle-housing. Thrust bearings (20) require only a few drops of SAE-10 Oil at intermittent periods.

The slide plate assembly (21) and feed screw (19) should be brushed and cleaned when abrasive grit and metallic dust accumulate on these assemblies. For access to this assembly, remove the base cover (28). To relubricate slide, apply a dry aerosol lubricant to exposed surface.

Variable Speed Sheave:

Single Belt Gerbing (Dura-cone) Variable Speed Sheave is permanently lubricated and does not require lubrication during its life. Replacement parts are not available.

The T.B. Woods single and multiple belt sheaves are fitted with an integral visi-lube intake tube supplying a constant flow of lubricant. An oil reservoir is mounted on top of base cover(28). The oil lever in reservoir will vary with the pitch diameter of the sheave. Oil reservoir should be filled when sheave is at its minimum pitch diameter (that's when the unit is operating with the smallest diameter wheel, and wheel spindle is

operating at its highest RPM). Filling when sheave is at maximum p.d. will cause oil to overflow as pitch diameter is decreased. The optimum time to check oil level is with each wheel change. With wheel removed, move the spindle assembly to its most forward position-, now fill the reservoir. Use AGMA #5EP oil (improper oil causes deterioration of "O" Rings).

Spindle Bearing Replacement:

Remove spindle nut (17), outer and inner flanges (15 & 18) and the retaining screws holding dust cap (11). Using a spanner wrench, remove bearing nut (13). P/N 13 on right hand spindle assemblies (wheel on right hand side) have RH threads, with LH assemblies having LH threads. Now remove the variable speed sheave (1) and bearing nut (3) (threads of P/N 3 are opposite of threads for P/N 13). Using pressure, press out spindle (7): this can be done in either direction. One bearing will remain on spindle, to be removed with bearing puller. The bearing remaining in the spindle housing should be removed by inserting rod through opposite end of housing and pressing against inner race bearing; light tapping on rod will remove bearing. **CAUTION – Excess hammering on the inner race will result in damaging the bearings.**

In re-assembling, insure that bearings and bearing surfaces are free of any foreign matter. Press one bearing on to spindle and the other bearing into spindle housing. Bearings are set by tightening bearing nuts (3 & 13).

Vibration:

Do not operate machine with wheels that are out of balance or out of round. An unbalanced wheel may be corrected by orienting the position of the wheel on the inner flange. To reposition wheel, release spindle nut 1/2 turn and rotate wheel independent of spindle, approximately 10 degrees. Secure hex nut and start machine. Repeat this process until unit is in balance. In most cases new wheels will have an inscription on the wheel itself indicating "top". This automatically locates the heaviest section of wheel and compensates for pilot diameter fit. If a wheel is out of round it must be "dressed" to a true diameter. Use a fixed dresser mounted on the tool rest.

Any vibration due to excessive slide clearance can be corrected by adjusting the Taper Gib (22) as follows:

1. Loosen Rear Gib Adjusting Screw Lock Nut (26) and back off on Gib adjusting screw (25). These items are accessible through top side plate on drive side of machine.
2. Loosen Front Gib Adjusting Screw Lock Nut (24) and move Front Gib Adjusting Screw(23) forward until all play is removed between Slide (21) and Taper Gib (22).
3. Secure Feed Screw (23) in position by tightening Lock Nut (24).
4. Turn Rear Adjusting Screw (25) until it is firmly seated against Taper Gib (22) and secure with Lock Nut (26).

A Maintenance Schedule should be set up based on severity of use.

PARTS:

When ordering replacement parts or referring to this machine always state **Model Number and Serial Number**.

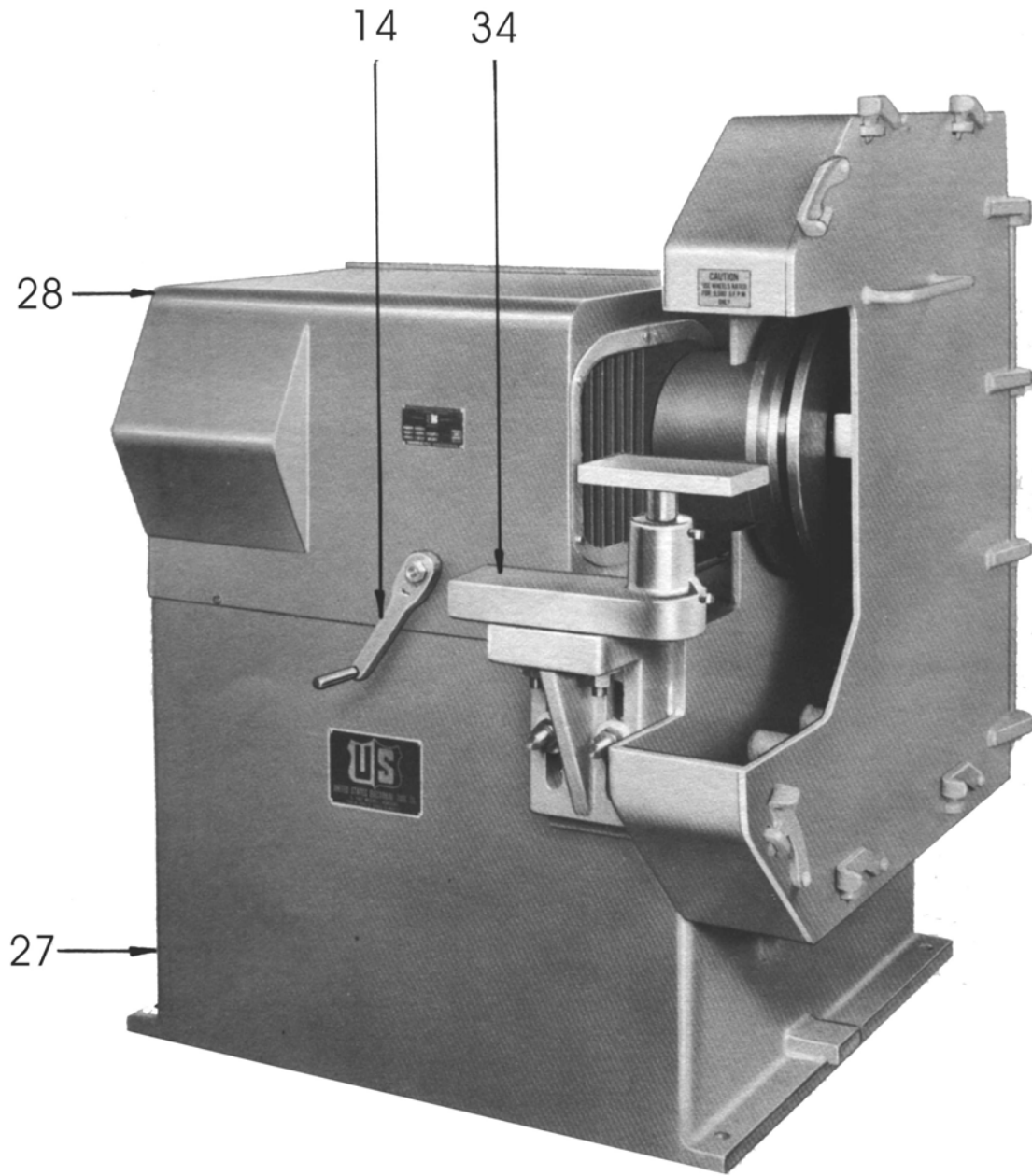

PARTS LIST

14	Ratchet Wrench	28	Base Cover
27	Base	34	Tool Rest Arm

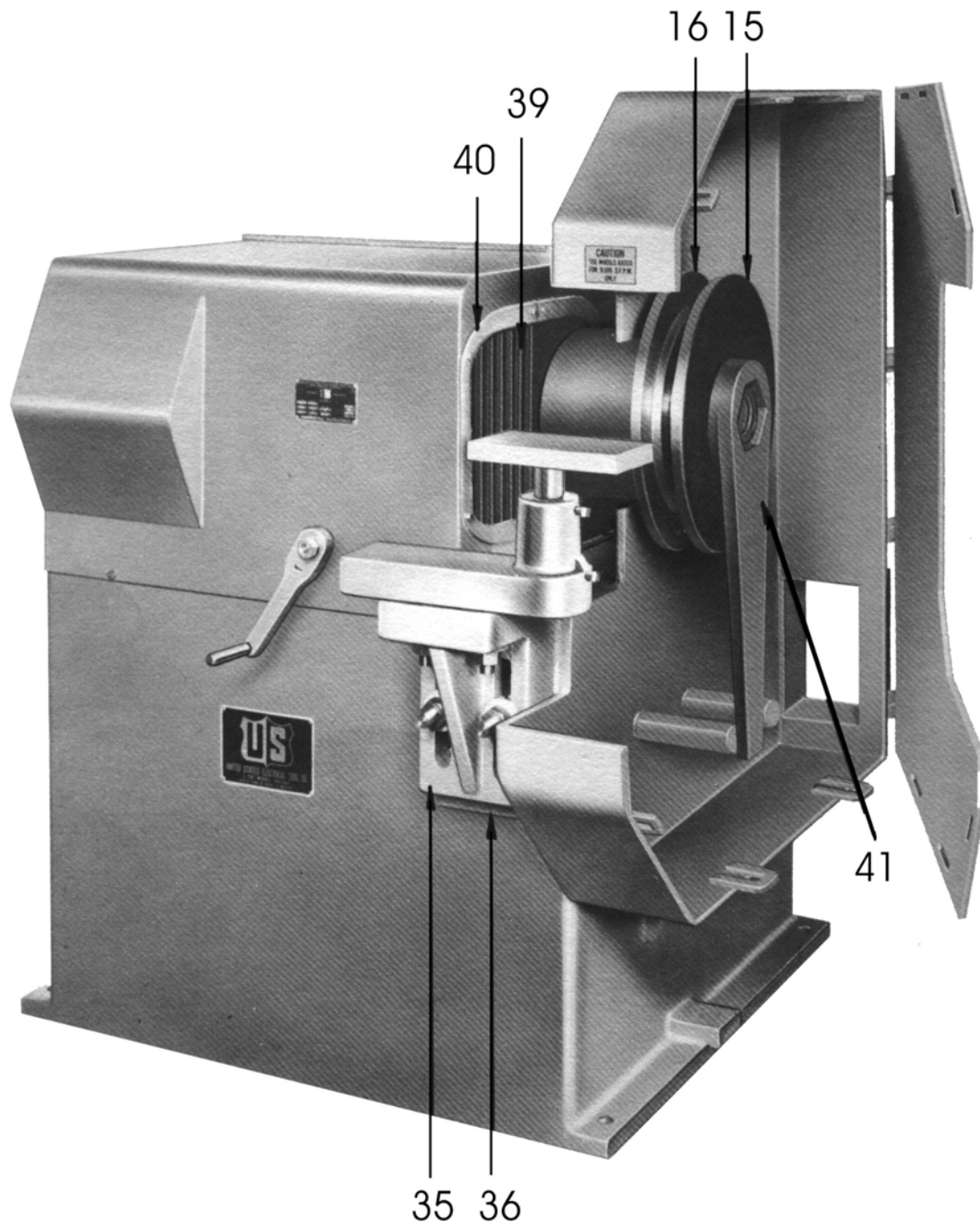

PARTS LIST

15	Wheel Flange, Outer	39	Bellows
16	Wheel Flange, Inner	40	Bellows Frame
35	Tool Rest Bracket	41	Spindle Nut Wrench
36	Tool Rest Adapter		

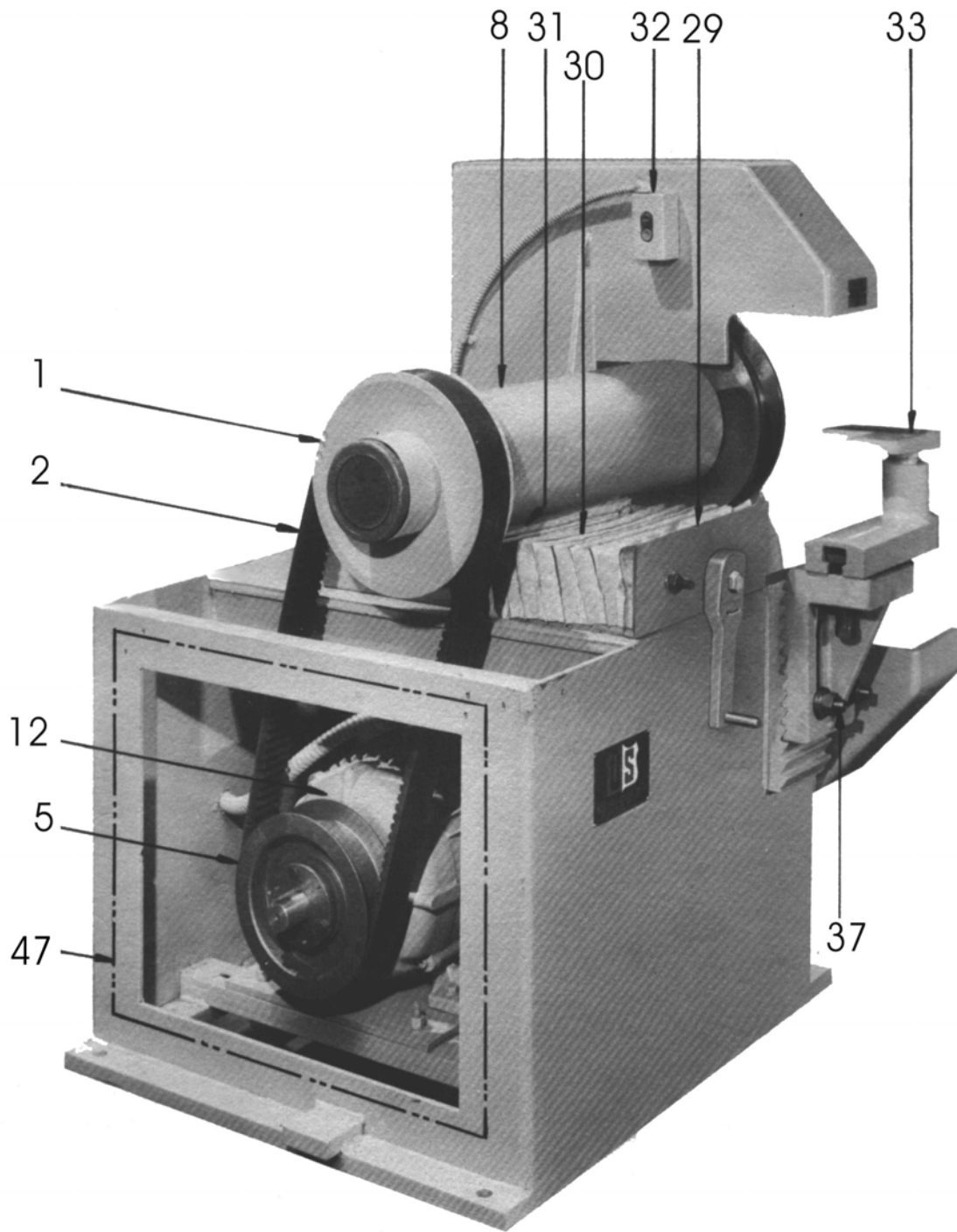

PARTS LIST

1	Variable Speed Sheave	12	Motor	32	Push Button Station
2	Variable Speed Belt	29	Front Plate	33	Tool Rest
5	Companion Sheave	30	Feed Screw Bellows	37	Tool Rest Stud
8	Bearing Housing	31	Rear Plate	47	Louver Door

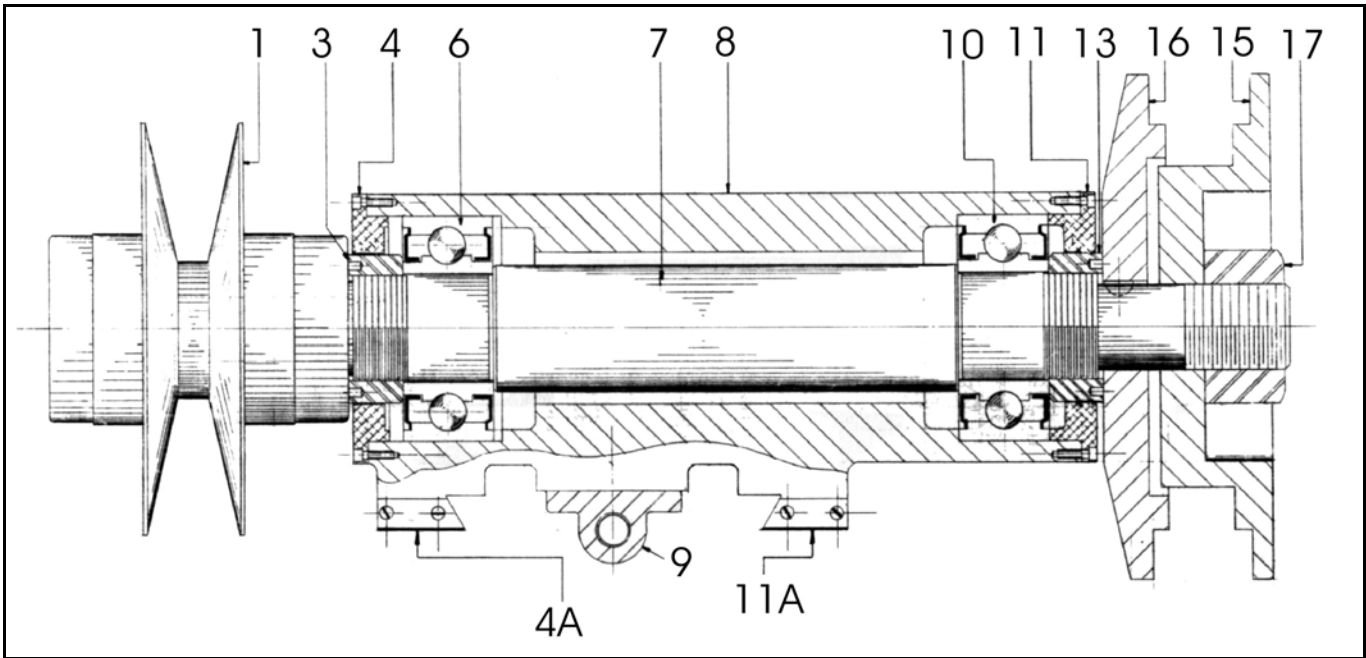

DRAWING: CA-1977

SPINDLE ASSEMBLY
PARTS LIST

1	Variable Speed Sheave	10	Ball Bearing
3	Bearing Lock Nut, LH	11	Dust Cap, Lock
4	Dust Cap, Float	11A	Slide Wiper
4A	Slide Wiper	13	Bearing Lock Nut, RH
6	Ball Bearing	15	Wheel Flange, Outer
7	Shaft, RH	16	Wheel Flange, Inner
8	Bearing Housing	17	Spindle Hex Nut, RH
9	Feed Screw Nut		

NOTE: Right Hand Assembly shown. For Left Hand Assembly, reverse threads.

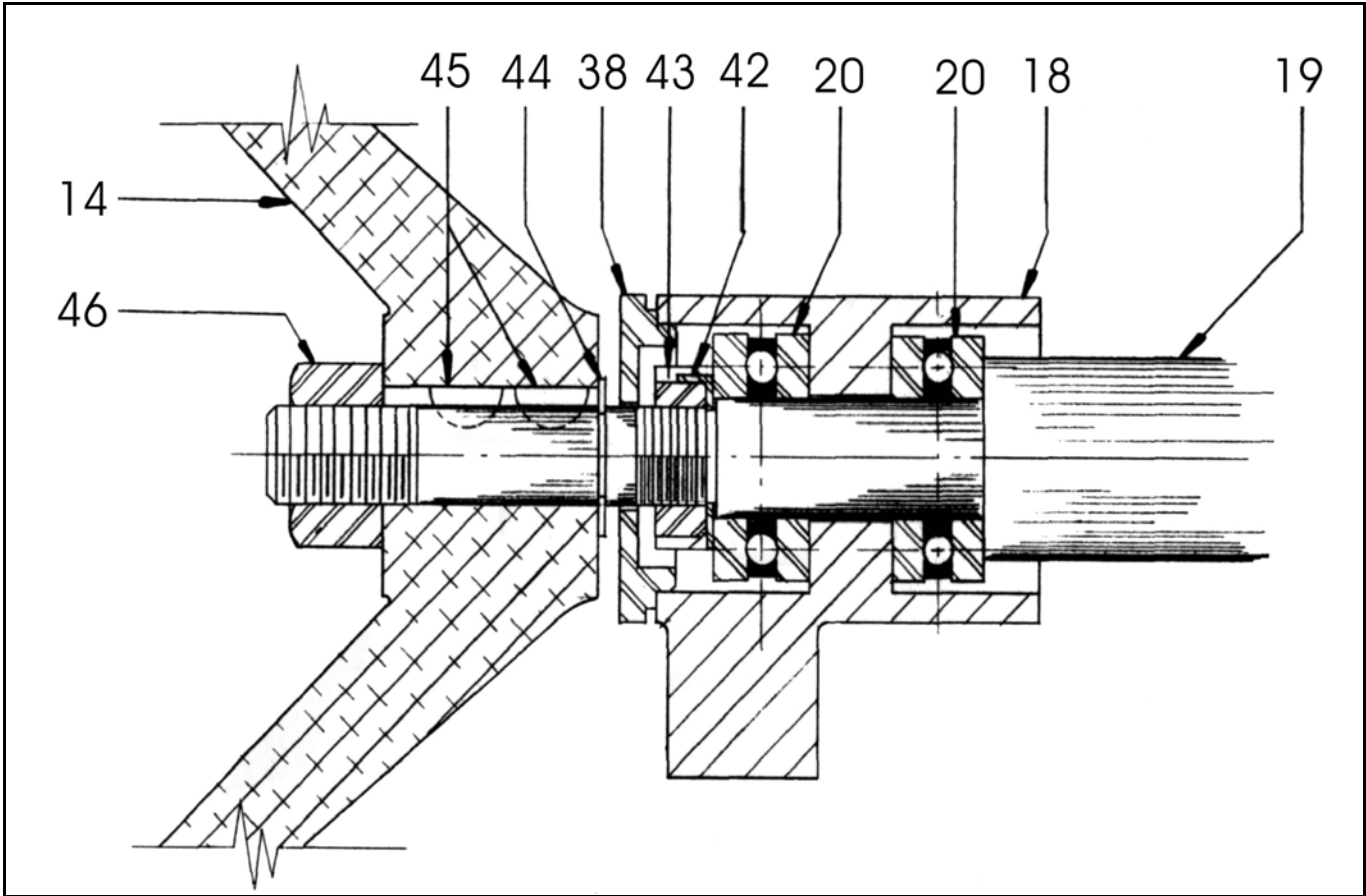

DRAWING: GA-7742

FEED SCREW ASSEMBLY
PARTS LIST

14	Hand Wheel ❖	42	Lock Washer
18	Feed Screw Bracket	43	Lock Nut
19	Feed Screw	44	Snap Ring
20	Thrust Bearing	45	Woodruff Key
38	Feed Screw Dust Cap	46	Hex Nut

❖ Or Ratchet Wrench and Bushing (not shown)

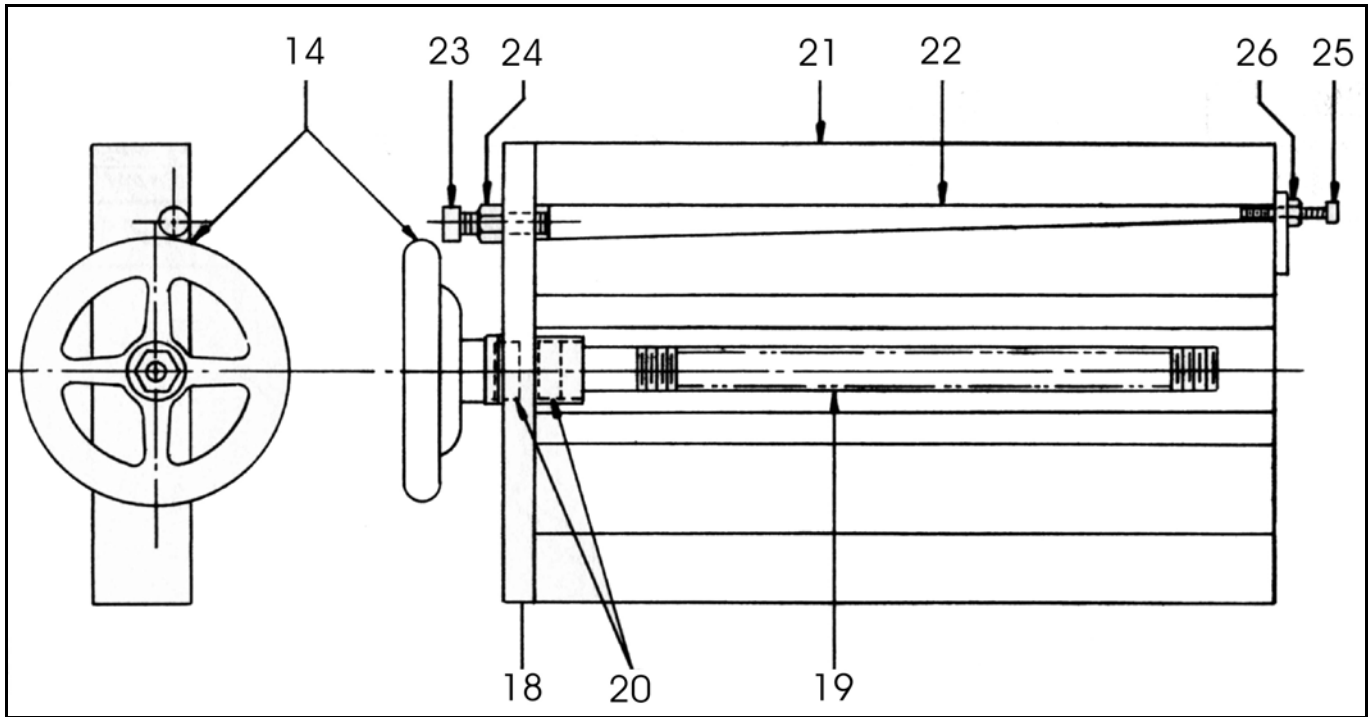

SLIDE PLATE ASSEMBLY
PARTS LIST

14 Hand Wheel ❖	22 Tapered Gib
18 Feed Screw Bracket	23 Gib Adjusting Screw, Front
19 Feed Screw	24 Adjusting Screw Lock Nut, Front
20 Thrust Bearing	25 Gib Adjusting Screw, Rear
21 Slide Plate	26 Adjusting Screw Lock Nut, Rear

❖ Or Ratchet Wrench and Bushing (not shown)

PARTS LIST
MODELS 61VSA & 62VSA

P/N	PART NAME	P/N	PART NAME
1	Variable Speed Sheave*	24	Adj. Screw Locknut (Front)
2	Variable Speed Belt*	25	Gib Adj. Screw (Rear)
3	Bearing Nut	26	Adj. Screw Locknut (Rear)
4	Dust Cap	27	Base
4A	Slide Wiper	28	Base Cover
5	Companion Sheave	29	Front Plate (Bellows Cover only)
6	Ball Bearing	30	Lead Screw Cover (Bellows or Telescopic)
7	Spindle	31	Rear Plate (Bellows Cover Only)
8	Spindle Housing	32	Push Button Station & Starter
9	Feed Screw Nut	33	Tool Rest
10	Ball Bearing	34	Tool Rest Arm
11	Dust Cap	35	Tool Rest Bracket
11A	Slide Wiper	36	Tool Rest Adapter
12	Motor	37	Tool Rest Stud
13	Bearing Nut	38	Feed Screw Dust Cap
14	Handwheel or Crank Handle	39	Bellows Shield
15	Outside Flange	40	Bellows Shield Retainer
16	Inside Flange	41	Wrench
17	Spindle Nut	42	Lock Washer
18	Feed Screw Bracket	43	Lock Nut
19	Feed Screw	44	Snap Ring
20	Thrust Bearing	45	Woodruff Key
21	Slide Plate	46	Hex Nut
22	Taper Gib	47	Louver Door
23	Gib Adj. Screw (Front)		

NOTES:

P/N 1 When replacement belts are required, for the 2 or 3 belt machines, order as either 1 Set of 2 Variable Speed Belts (MATCHED) or as 1 Set of 3 Variable Speed Belts (MATCHED). It is necessary that the belts for the 2 and 3 belt machines be furnished in matched sets to insure proper fit and to balance the pulling power of each belt.

When ordering replacement parts for the Model 62VSA Double-End Grinder, specify for either the Right or Left Hand assembly, or side. All part numbers and part names are the same, whether for the 61 or 62VSA.

P/N 2 When replacement parts are required for the variable speed sheave, please order these by the part numbers or kit numbers and part names, as indicated in Section II. Also specify whether for the 1 Belt - MCS-12W or MCS-10W, 2 Belt - MS-1 10 R2, or the 3 Belt - MS1 10 R3 Sheaves.

**WHEN CONTACTING THE FACTORY ABOUT YOUR UNIT,
ALWAYS STATE THE MODEL AND SERIAL NUMBER OF UNIT.**